

90 Degree Stepper Motors Size 8

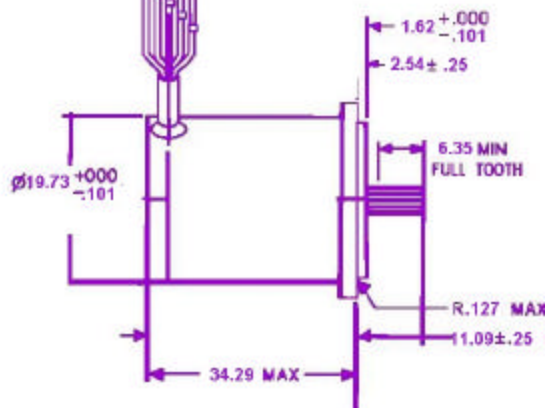
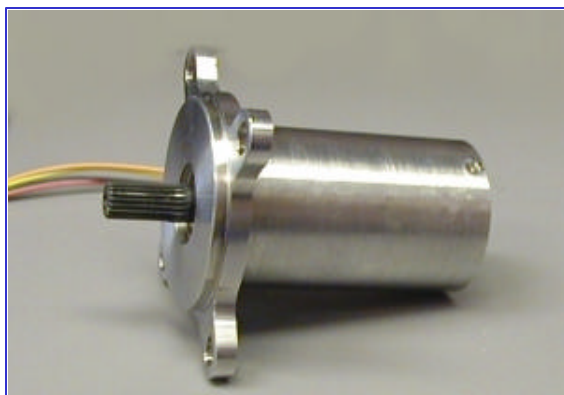

Unipolar Windings

	-101	-102
Pulse Rate (pps max)	150	150
Km (Nm/ $\sqrt{\text{watts}}$)	.007	.007
Running torque @60 pps (Nm)	.008	.008
Holding torque (Nm)	.019	.019
Detent torque (Nm)	.004	.004
Kt (Nm/amp)	.055	.028
Phase resistance (ohms)	68	18
Power - Single Winding (watts)	8.5	8.5

Bipolar Windings

	-101	-102
Pulse Rate (pps max)	150	150
Km (Nm/ $\sqrt{\text{watts}}$)	.010	.010
Running torque @61 pps (Nm)	.008	.008
Holding torque (Nm)	.019	.019
Detent torque (Nm)	.003	.003
Kt (Nm/amp)	.11	.55
Phase resistance (ohms)	135	34
Power - Single Winding (watts)	4.2	4.2

Pulse Rate (pps max)
Km (Nm/ $\sqrt{\text{watts}}$)
Running torque @60 pps (Nm)
Holding torque (Nm)
Detent torque (Nm)
Kt (Nm/amp)
Phase resistance (ohms)
Power - Single Winding (watts)

4x $\phi 3.37^{+.152}_{-.000}$
 $\phi 2.56$ ABS

Pulse Rate (pps max)
Km (Nm/ $\sqrt{\text{watts}}$)
Running torque @61 pps (Nm)
Holding torque (Nm)
Detent torque (Nm)
Kt (Nm/amp)
Phase resistance (ohms)
Power - Single Winding (watts)

Features

- Space Qualified
- Available with pinion for gearhead applications
- Unipolar or Bipolar drive winding options available
- Ceramic or steel ball bearing options are available
- Dry or wet lubrication options are available
- All materials are compliant with NASA outgassing requirements

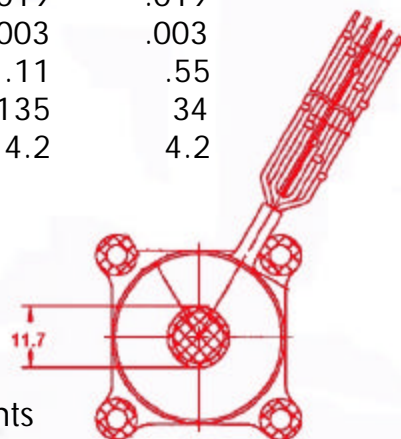

Motion Control Systems Division

350 Kennedy Drive
Hauppauge, NY 11788
Phone: (631) 231-9100

F-Mail sales-motion@aeroflex.com

