

Standard Products
SSGD5390
Solid State Gas Detector

www.aeroflex.com

November 30, 2007



FEATURES

- ❑ Solid State Reliability
- ❑ Low Power Consumption
- ❑ High Sensitivity
- ❑ Low Humidity Dependency
- ❑ No Calibration Required – Long Life
- ❑ Venturi Filtration System
- ❑ Ruggedized for Harsh Environmental use
- ❑ Analog Output Proportional to Gas ppm
- ❑ BITE Output
- ❑ Packaging
 - 4.0" x 6.0" x 2" (See Figure 2)
 - Weight - 1.5 lbs max
- ❑ Designed for Industrial, Aerospace and Military Applications



APPLICATION CHARACTERISTICS

- ❑ Gas Detection (CO, O₂, H)
- ❑ Replaces Unstable Chemical Sensor Components
- ❑ Continuous update of gas concentration measurements

DESCRIPTION

The Aeroflex Plainview Solid State Gas Detector module (SSGD5390) is designed to detect low levels of gases easily and rapidly. The technical approach has resulted in a safe, highly reliable, accurate, rapid response and low power stand-alone module. The design and fabrication will operate in the harshest environments.

The unique feature of this module is the continuous update of gas concentration readings, in parts-per-million by volume, to alert or to shut down systems operations prior to dangerous conditions.

Available screened to the test methods of MIL-STD-883, the SSGD5390 is ideal for demanding industrial, aerospace and military applications.

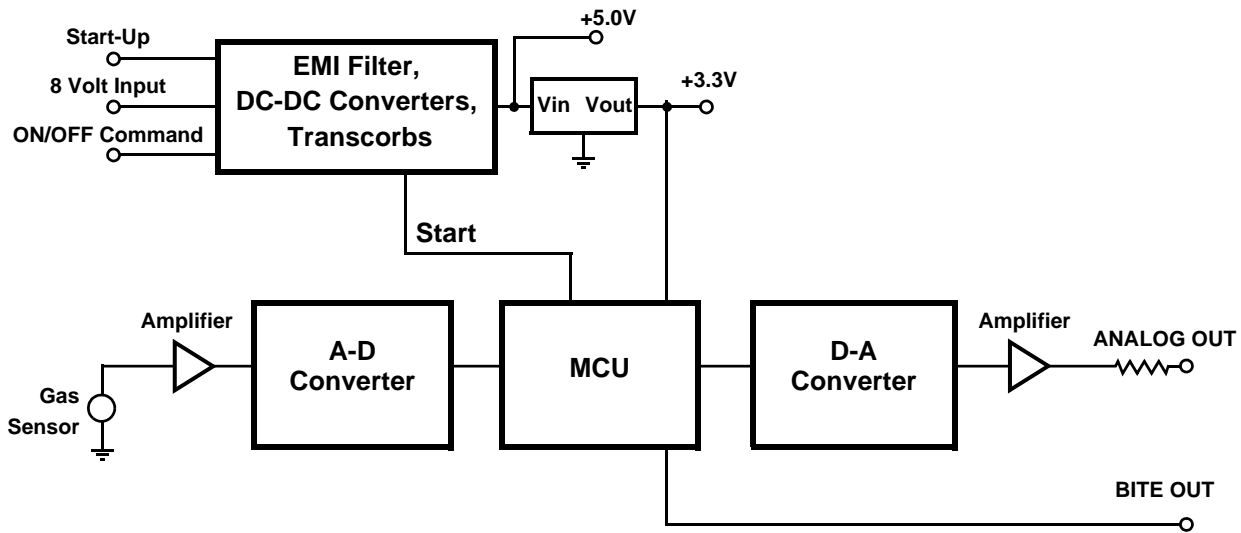

Figure 1 – Simplified Block Diagram of Gas Detector Module

FUNCTIONAL DESCRIPTION

Aeroflex Plainview uses a solid state gas detector as shown in the simplified block diagram of Figure 1. The circuit design consists of a sensor, a microcontroller (MCU), a detector amplifier, an output amplifier, DC-DC converters, and voltage regulators to provide the appropriate bias to the integrated circuits (+5V and +3.3V). Additional support components such as EMI filtering and tranzorbs are included to condition the raw power supply input voltages.

The gas detector receives System Startup Command data to control the MCU Initialization as well as receiving a gas detector ON/gas detector OFF mode signal from a computer.

The amplifier measures the current variations produced by the gas sensor. These variations vary linearly with the ppm of gas levels. These variations are then translated into voltages and are fed to the 10 bit Analog-to-Digital converter (ADC). The output value of the ADC is then processed by the MCU, based on the firmware algorithms, in order to determine if the maximum preset gas ppm level has been reached.

The gas sensor characteristics are stored in a look up table that compensates for zero offset (down to 25 ppm), temperature extremes, and non linear sensor properties. The compensated ADC output digital signal is then converted back to analog by a 10 bit Digital to Analog Converter. The output amplifier gain is controlled by the MCU to have gains of gains of 1, 2, 5, 10, 20, 50, or 100 when commanded by the computer to report all sensor data.

The MCU will pulse the analog outputs at a rate of 100 Hz or 400 Hz. The gas sensor measures a 25 ppm gas level and has a ± 5 ppm accuracy.

The gas detector provides a fault signal to indicate a malfunction of the MCU or the gas sensor.

ABSOLUTE MAXIMUM RATINGS

Supply Voltage	32VDC
Operating Temperature	+85°C

RECOMMENDED OPERATING CONDITIONS

Parameter	Minimum	Typical	Maximum
Supply Voltage	7VDC	+8VDC	+30VDC
Power Consumption	0.5W	1.0W	2.0W

SPECIFICATIONS

Model Number			SSGD5390
Sensing Element Type			M1
Standard Package			Metal Module
Sampling Gases			Carbon Monoxide
Typical Detection Range			25 ~ 1000 ppm
Typical Circuit Conditions	Heater voltage cycle	V _H	V _H = 4.8V±0.2Vdc, 14ms V _L = 0.0, 986ms
	Circuit voltage cycle	V _C	V _C = 5.0V for 995ms, V _C = 5.0V ±0.2VDC fo 5ms
	Load resistance	R _L	variable (>10KW)
Electrical Characteristics under standard test conditions	Heater resistance	R _H	17Ω ±2.5Ω at room temp.
	Heater current	I _H	approx. 203mA (in case of V _H)
	Heater power consumption	P _H	approx. 14mΩ (Average)
	Sensor Resistance	R _S	13.3KΩ ~ 133KΩ in 100ppm of Carbon Monoxide
	Sensitivity (change ratio of R _S)	β	0.13 ~ 0.31
Standard Test Conditions	Test gas conditions		Carbon Monoxide in air at 20°C ±2°C, 65 ± 5%RH
	Circuit conditions		Same as standard circuit condition (above)
	Conditioning period before test		2 days or more

Sensor resistance (R_s) is calculated with a measured value of V_{out} as follows:

$$R_s = \frac{V_{cx} R_L}{V_{out}} - R_L$$

The value of sensitivity (β) is calculated with two measured values of R_s as follows:

$$\beta = \frac{R_s(\text{CO}, 300\text{ppm})}{R_s(\text{CO}, 100\text{ppm})}$$

CONTROL CONNECTOR PINOUT
15pin MIL-DTL-38999 Series III

Pin#	Default level	Signal
1	7V - 28V	Power
2	H	RS232 TxD
3	H	RS232 RxD
4	GND1	Return
5	GND2	RS232 & CAN Ground
6	H	CAN L
7	L	CAN H
8	-	J1939-SA0
9	-	J1939-SA1
10	0V/5V	On/Off (Input)
11	0V/5V	Fault (Output) (Bite)
12	-	Analog Gas Level
13	0V/5V	Alarm
14	-	Option 1
15	-	Option 2

Notes:

- Option 1 – Digital representation of gas ppm
- Option 2 – Start on power up - no computer control
 (Consult factory for details on options)

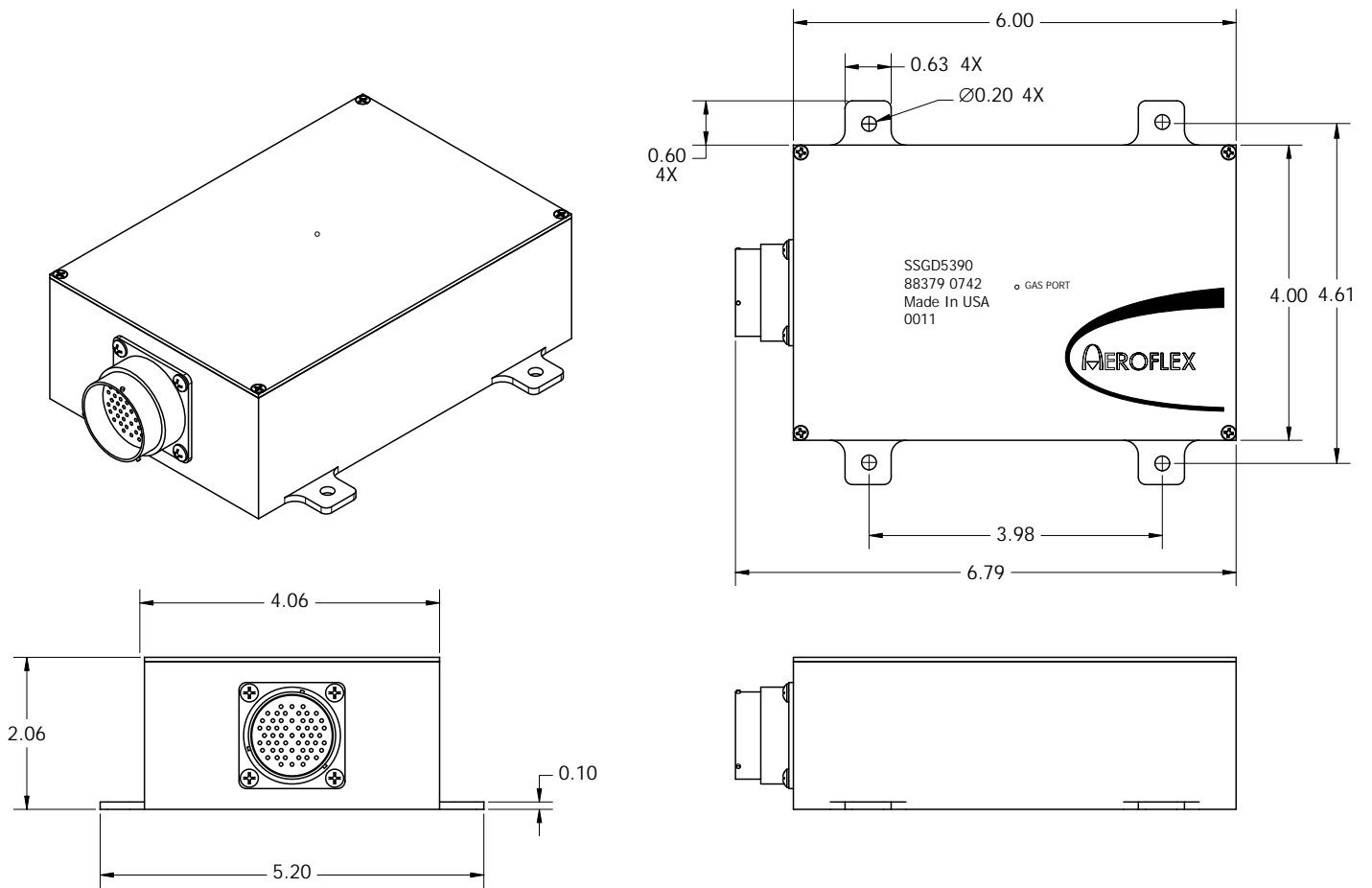

Figure 2 – Gas Detector Module Outline

ENVIRONMENTAL DATA

Test	Limits
Operational Temperature Range	-40°C to +85°C
Storage Temperature Range	-55°C to +125°C
Vibration	20g, 20 – 2000Hz
Acceleration	1,000g
Shock	1,000g, 0.5ms
MTBF	150,000 hrs

ORDERING INFORMATION

Model	Sensor	Screening	Package
SSGD5390	CO	Temperature -40°C to +85°C Screened in accordance with test methods per MIL-STD-883	See Figure 2
SSGD5391	O ₂		
SSGD5392	H		

PLAINVIEW, NEW YORK
Toll Free: 800-THE-1553
Fax: 516-694-6715

INTERNATIONAL
Tel: 805-778-9229
Fax: 805-778-1980

NORTHEAST
Tel: 603-888-3975
Fax: 603-888-4585

SE AND MID-ATLANTIC
Tel: 321-951-4164
Fax: 321-951-4254

WEST COAST
Tel: 949-362-2260
Fax: 949-362-2266

CENTRAL
Tel: 719-594-8017
Fax: 719-594-8468

www.aeroflex.com info-ams@aeroflex.com

Aeroflex Microelectronic Solutions reserves the right to change at any time without notice the specifications, design, function, or form of its products described herein. All parameters must be validated for each customer's application by engineering. No liability is assumed as a result of use of this product. No patent licenses are implied.



Our passion for performance is defined by three attributes represented by these three icons: solution-minded, performance-driven and customer-focused